

FSP 3000

Open, secure and efficient Terascale networking

Benefits

- Scalability**
 Up to 9.6THz bandwidth capacity per fiber (C+L band); coherent pluggable optics up to 800Gbit/s
- Flexibility**
 From complete turnkey systems, including all equipment necessary for end-to-end transport applications, to disaggregated solutions
- Pay-as-you-grow design**
 Modular and scalable architecture, with hot-swappable modules and pluggable optics that ensures both low initial cost and flexibility into the future
- Fully open and programmable**
 Open line system (OLS) architecture and YANG-based APIs (OpenConfig) for network disaggregation and easy integration into SDN-based environments
- Dynamic and scalable optical layer**
 Fixed- (FOADM), broadcast- (BOADM), and flexgrid reconfigurable optical add/drop multiplexer nodes (ROADM) with multiple add/drop options
- Quantum-safe encryption technology**
 Certified Layer 1 encryption with ultra-low latency and 100% throughput. PQC cryptography with hybrid key exchange system, QKD support and crypto-agility

Overview

The FSP 3000 is an open, scalable optical transport platform that delivers high-capacity, secure and cost-efficient connectivity from the edge to the network core.

As bandwidth demand, cloud applications, and SDN adoption continue to grow, operators and enterprises require scalable and efficient solutions that can easily evolve with their needs. The FSP 3000 is built for this environment, delivering up to 9.6 THz of bandwidth while reducing operational complexity, lowering cost per bit and ensuring reliable, high-capacity transport at scale.

With its open, modular design and broad portfolio of open line systems, optical terminals and coherent pluggable transceivers, our FSP 3000 supports a wide range of services and applications, from data center interconnect (DCI) of any type and scale to carrier-optimized infrastructure, delivering consistent performance and flexibility across the network.

Built-in, certified security technologies, including post-quantum cryptography (PQC) and crypto-agility, protect data in motion against evolving cyber threats, including future quantum computer attacks, with minimal impact on latency, cost, or complexity. Its high-density, energy-efficient design also supports compliance with the most stringent sustainability requirements.

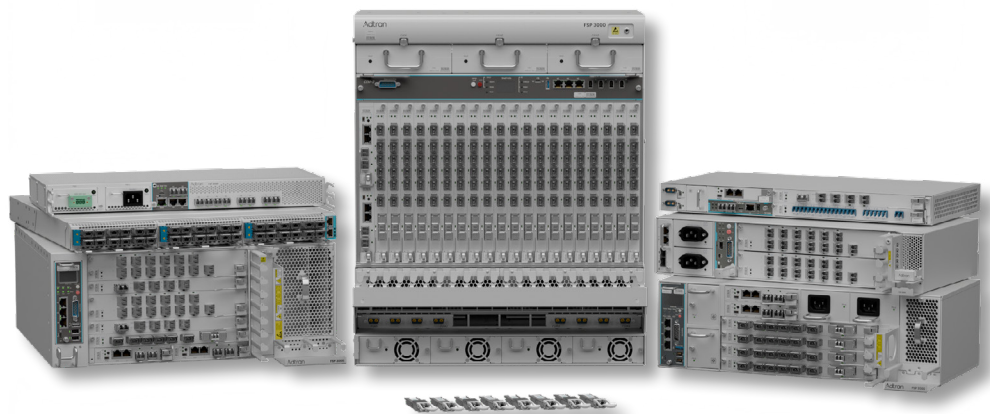

FSP 3000

Applications in your network

Open optical transport network infrastructure from the edge to the core

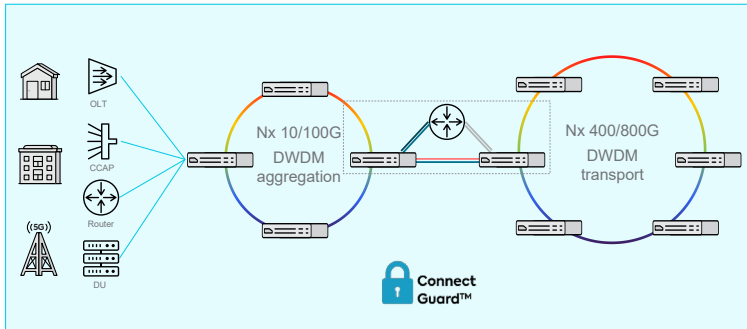

Small and hyperscale data center interconnect (DCI)

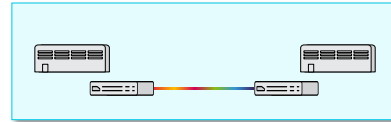

Enterprise DCI for business continuity and disaster recovery

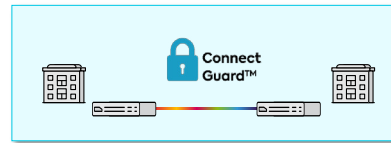

End-to-end network infrastructure

- Open optical networking solutions for turnkey as well as disaggregated, multi-vendor use cases
- Tailor-made solutions for edge, metro and core optical network infrastructure
- Highly secure and reliable critical infrastructure

DCI for AI, cloud and business continuity applications

- High-speed, secure and reliable connections between data centers spread across different geographical locations
- Purpose-built innovation for SAN-, mainframe- and Ethernet-based DCI
- Open hardware architecture and YANG-based software (OpenConfig) modelling for easy integration into SDN-based environments

FSP 3000

Product specifications

Wavelength technologies

- DWDM:
 - Filter-based multiplexing with 50, 75, 100, 150, 200 and 400GHz spacing options
 - Flexgrid with channel width granularity down to 6.25GHz
- CWDM:
 - Up to 16 wavelengths/20nm according to ITU-T G.694.2

Topologies

- Point-to-point
- Point-to-multipoint
- Linear add/drop
- Multiplexed add/drop (drop and continue)
- Ring (+ feeder + dual homing)
- Hubbed-ring
- Meshed

Services

- From 100Mbit/s to 850Gbit/s
- Ethernet: FE, GbE, 10GbE (LAN and WAN), 25GbE, 40GbE, 100GbE, 400GbE and 800GbE; 10G, 25G, 100G, 400G RoCE; 10G, 25G CE LR
- Fibre Channel/FICON up to 64Gbit/s
- InfiniBand 5G and 10G
- STM-1, -4, -16, -64 / OC-3, -12, -48, -192
- OTU-1, -2, -3 and -4, OTUCn
- CPRI up to 25Gbit/s speeds (eCPRI)

Service protection and restoration

- Options based on
 - ROADM-based optical layer restoration
 - Optical switches
 - Redundant cards
 - OTN path protection

Optical terminals

- Suite of
 - Coherent pluggable optics
 - Multi-rate, multi protocol trans-/muxponders
 - Multi-rate, multi protocol trans-/muxponders with integrated low-speed OTN switching
- Coherent optics based solutions
- Line speeds up to 800Gbit/s
- Variants with built-in ConnectGuard™ layer 1 encryption technology
- 10Gbit/s QSFP-based service multiplexer

ConnectGuard™ encryption

- Layer 1 AES-256 hardware encryption with ultra-low latency and 100% throughput
- FIPS 140-2 and CC EAL-2 certified
- Germany's Federal Office for Information Security (BSI) approval for transport of classified data up to German "VS-V" or NATO "confidential"
- Automatic key rotation every minute for forward secrecy enhancement
- Hybrid key establishment with post-quantum cryptography (PQC, in accordance with FIPS 203 and NIST SP 800-56C)
- Third-party quantum key distribution (QKD) support as per ETSI GS 014

Optical layer

- 9.6THz spectrum bandwidth (C+L bands)
- Filter-based multiplexing with 50, 75, 100, 150, 200 and 400GHz spacing options
- Flexgrid reconfigurable optical add/drop modules (ROADM) from 1 to 32 degrees with multiple fixed, colorless, directionless and contentionless add/drop structures
- Broadcast optical add/drop modules (BOADM) optimized for next-gen optical edge networks
- Optical amplification options using Erbium fiber (EDFA) and integrated EDFA+Raman amplifiers
- Automated optical layer with channel equalization and span loss equalization
- Optical supervisory functions like optical channel monitoring with full support of third-party wavelengths
- Tailored solutions for access, metro and long-haul infrastructure, and for ZR-based interconnects
- Optical timing channel (OTC)
- Fiber monitoring (OTDR)

Common equipment

- Variety of active chassis from 1RU to 12RU; 300mm and 600mm depth variants
- 19in/ETSI/NEBS rack mounting
- Hardened ETSI-compliant 1RU shelf suitable for outdoor deployments, such as street cabinets
- Fully redundant power supply modules; AC, DC, and mixed AC/DC options
- Hot-swappable (non traffic affecting) controller modules

FSP 3000

Equipment and network management

- Embedded CRAFT/CLI
- Embedded web-based graphical user interface with “point and click” provisioning via HTTPS
- Full support of SNMP, TLI, REST, NETCONF (OpenConfig)
- Streaming telemetry (gRPC)
- Full support of FTP, SFTP, SCP, SSH, TELNET
- Remote authentication via RADIUS or TACACS+
- Equipment management using DCN or in-band management tunnels
- Enhanced user management with multiple security options
- Zero-touch provisioning methods using automated set-up, scripting environment like Ansible and network-wide profile management
- Guided installation and fault identification
- Mosaic Network Controller network management system and domain control with T-API

Laser safety

- Class 1M laser product with hazard Level 1M

Environmental

- Standard temperature (operating): +5°C to +40°C
- Extended temperature active (operating): -40°C to +65°C
- Extended temperature passive: -40°C to 85°C
- Relative humidity (non-condensing): 5% to 85% (operating) / 5% to 90% (short-term)
- Outdoor enclosures for passive components

Regulatory compliance

- ETSI EN 300 019-1-1 V2.2.1 Storage class 1.2
- ETSI EN 300 019-1-2 V2.2.1 Transportation class 2.2
- ETSI EN 300 019-1-3 V2.4.1 Stationary use at weather protected locations class 3.1
- ETSI EN 300 019-2-3 V2.4.1 Non- temperature controlled, weather protected locations Class 3.3E (-40°C to max +65°C) for extended temperature shelf configurations
- NEBS level 3
- Laser safety: IEC 60825-1, IEC 60825-2, ITU-T G.664-2012
- EMC: CISPR 22, CISPR 24 / CISPR 32, CISPR 35
- Product safety: IEC 60950-1, IEC 62368-1:2014
- Directive 2011/65/EU (RoHS II) and 2015/863/EU (RoHS III)
- WEEE: directive 2012 / 19 / EU, EN 50419:2006
- IP20. Use in a pollution degree 2 environment and indoor controlled office environments only
- CE declaration of conformity
- FCC supplier's declaration of conformity
- WCAG 2.0 certification for embedded web GUI

